

RE-716SO

CONVENTIONAL SOUNDER / HORN

General

The sounder is designed to reliable safety solution with UL certification and dual tone auditable settings. For Continuous and temporal 3 tones available. It can deliver the sounder output range between 75db to 85db.

Features

- UL 464, UL - S525.
- 2 Audible Tones Settings : Continuous and Temporal 3.
- Low current consumption device.
- FIRE label visibility from all direction.
- 24VDC Operation.
- Used in Fire, Burglar & Emergency Alarm System.



Specification

	Electrical Specification
Max. Current Draw	25mA
Operating Voltage	24V DC(16-33 VDC)/FWR
Mounting Options	Standard 4" *4" Back box
Sounder Output	75dB to 85dB
Compliance	UL 464, UL-S525
Operating Temperature	0 - 49° C / 32-120° F
Storage Temperature	0°C to 60°C
IP Rating	IP 40
Wiring Type	2
Screw Terminals	#12 to #18 AWG Wires
Dimension	(140 L x 120 W x 51 D) mm

Wiring Details

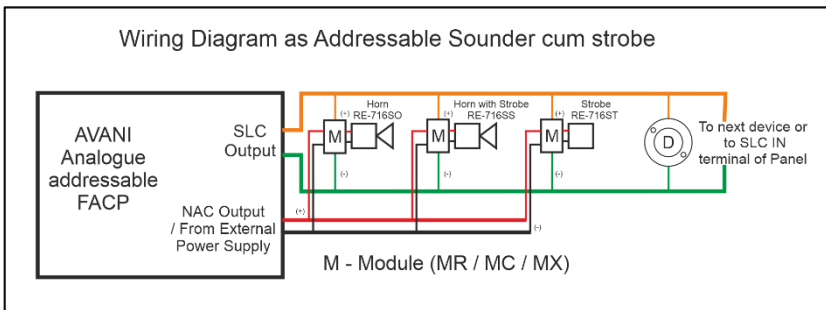
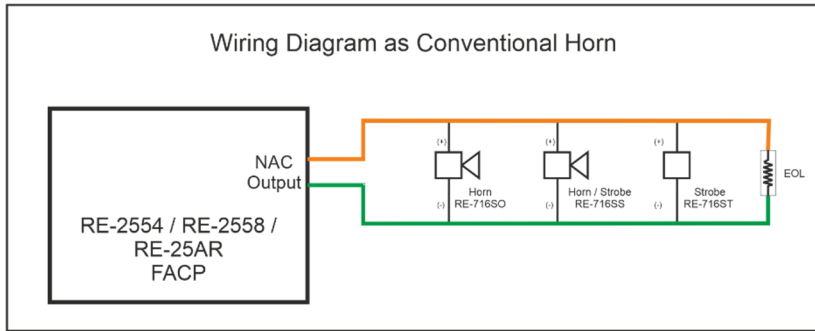

Compatible Panel

Model	Description
AVANI	Analogue addressable Fire Alarm Control panel expandable upto 4 loop
Avani db	Analogue Addressable Fire Alarm Control panel expandable upto 2 loop
Avani XL	Analogue Addressable Fire Alarm Control Panel expandable upto 8 Loop
RE-25AR	Conventional Agent Release Control Panel
RE-2558/2554	Conventional 8 IDC / 4 IDC Fire Alarm Control Panel

Compatible Device

Model	Description
RE-717MC	Addressable Control Module
RE-717MR	Addressable Relay Module
RE-717MX	Addressable Input Output Module

Ordering Information

Model	Description
RE-716SO	Conventional Sounder / Horn

India

RAVEL ELECTRONICS PVT LTD.,
150A, Electronics Industrial Estate,
Perungudi, Chennai – 96, India.
E-mail: marketing@ravelfire.com; Web: www.ravelfire.com

United Kingdom

RAVEL ELECTRONICS LTD.,
Unit 11, Chancel Industrial Estate, Newhall street,
Willenhall WV13 1NX, West Midlands, United Kingdom.
E-mail: info@ravelfire.co.uk; Web: www.ravelfire.co.uk

USA

RAVEL AMERICAS INC.,
2855 NW 112th Ave ST#2 Miami,
Doral, Florida 33172, USA.